

High-Z, Programmable Gain, Differential Amplifier

Features

- Signal Bandwidth: DC to 2 kHz
- Selectable Gain: x1, x2, x4, x8, x16, x32, x64
- Differential Inputs, Differential Outputs
 - Multiplexed inputs: INA, INB, 800Ω termination
 - Rough / fine charge outputs for CS5371A / 72A / 73A
 - Max signal amplitude: 5 V_{pp} differential
 - Ultra-low input bias: < 1 pA
- Excellent Noise Performance
 - 1 μV_{p-p} between 0.1 Hz and 10 Hz
 - 8.5 nV/√Hz from 200 Hz to 2 kHz
- Low Total Harmonic Distortion
 - -118 dB THD typical (0.000126%)
 - -112 dB THD maximum (0.000251%)
- Low Power Consumption
 - Normal operation: 5 mA
 - Power down: 10 μA
- Dual Power Supply Configuration
 - VA+ = +2.5 V; VA- = -2.5 V; VD = +3.3 V

Description

The CS3302A is a high input-impedance, differential input, differential output amplifier with programmable gain, optimized for amplifying signals from high-impedance sensors such as hydrophones. The gain settings are binary weighted (x1, x2, x4, x8, x16, x32, x64) and are selected using simple pin settings. Two sets of external inputs, INA and INB, simplify system design as inputs from a sensor and test DAC. An internal 800Ω termination can also be selected for noise tests.

Amplifier input impedance is very high, requiring less than 1 pA of input current. Noise performance is very good at 1 μV_{p-p} between 0.1 Hz and 10 Hz, and a noise density of 8.5 nV/√Hz over the 200 Hz to 2 kHz bandwidth. Distortion performance is also extremely good, typically -118 dB THD. Low input current, low noise, and low total harmonic distortion make this amplifier ideal for high-impedance differential sensors requiring maximum dynamic range.

ORDERING INFORMATION

See [page 15](#).

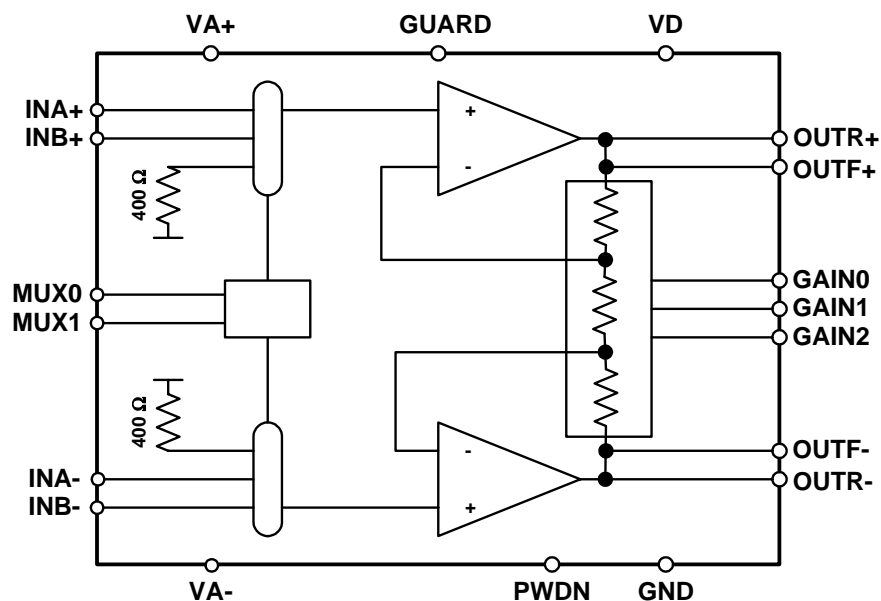

TABLE OF CONTENTS

1. CHARACTERISTICS AND SPECIFICATIONS	4
SPECIFIED OPERATING CONDITIONS	4
ABSOLUTE MAXIMUM RATINGS	4
THERMAL CHARACTERISTICS	5
ANALOG CHARACTERISTICS	5
DIGITAL CHARACTERISTICS	8
POWER SUPPLY CHARACTERISTICS	9
2. GENERAL DESCRIPTION.....	10
2.1. Analog Signals	10
2.2.1. Analog Inputs	10
2.3.2. Analog Outputs	11
2.4.3. Differential Signals	11
2.5.4. Guard Output	11
2.6. Digital Signals	12
2.7.1. Gain Selection	12
2.8.2. Mux Selection.....	12
2.9.3. Power Down Selection	12
2.10. Power Supplies	12
2.11.1. Analog Power Supplies	12
2.12.2. Digital Power Supplies	12
2.13. Connection Diagram	13
3. PIN DESCRIPTION	14
4. ORDERING INFORMATION	15
5. ENVIRONMENTAL, MANUFACTURING, & HANDLING INFORMATION	15
6. PACKAGE DIMENSIONS.....	16

LIST OF FIGURES

Figure 1. CS3302A Noise Performance.....	5
Figure 2. Digital Input Rise and Fall Times	8
Figure 3. System Architecture.....	10
Figure 4. System Architecture.....	11
Figure 5. CS3302A Amplifier Connections.....	13
Figure 6. CS3302A Pin Assignments.....	14

LIST OF TABLES

Table 1. Digital Selection for Gain and Input Mux Control	8
Table 2. Pin Descriptions	14

REVISION HISTORY

Revision	Date	Changes
PP1	NOV 2007	Initial release.

Contacting Cirrus Logic Support

For all product questions and inquiries contact a Cirrus Logic Sales Representative.
To find one nearest you go to www.cirrus.com

IMPORTANT NOTICE

"Preliminary" product information describes products that are in production, but for which full characterization data is not yet available.

Cirrus Logic, Inc. and its subsidiaries ("Cirrus") believe that the information contained in this document is accurate and reliable. However, the information is subject to change without notice and is provided "AS IS" without warranty of any kind (express or implied). Customers are advised to obtain the latest version of relevant information to verify, before placing orders, that information being relied on is current and complete. All products are sold subject to the terms and conditions of sale supplied at the time of order acknowledgment, including those pertaining to warranty, indemnification, and limitation of liability. No responsibility is assumed by Cirrus for the use of this information, including use of this information as the basis for manufacture or sale of any items, or for infringement of patents or other rights of third parties. This document is the property of Cirrus and by furnishing this information, Cirrus grants no license, express or implied under any patents, mask work rights, copyrights, trademarks, trade secrets or other intellectual property rights. Cirrus owns the copyrights associated with the information contained herein and gives consent for copies to be made of the information only for use within your organization with respect to Cirrus integrated circuits or other products of Cirrus. This consent does not extend to other copying such as copying for general distribution, advertising or promotional purposes, or for creating any work for resale.

CERTAIN APPLICATIONS USING SEMICONDUCTOR PRODUCTS MAY INVOLVE POTENTIAL RISKS OF DEATH, PERSONAL INJURY, OR SEVERE PROPERTY OR ENVIRONMENTAL DAMAGE ("CRITICAL APPLICATIONS"). CIRRUS PRODUCTS ARE NOT DESIGNED, AUTHORIZED OR WARRANTED FOR USE IN AIRCRAFT SYSTEMS, MILITARY APPLICATIONS, PRODUCTS SURGICALLY IMPLANTED INTO THE BODY, AUTOMOTIVE SAFETY OR SECURITY DEVICES, LIFE SUPPORT PRODUCTS OR OTHER CRITICAL APPLICATIONS. INCLUSION OF CIRRUS PRODUCTS IN SUCH APPLICATIONS IS UNDERSTOOD TO BE FULLY AT THE CUSTOMER'S RISK AND CIRRUS DISCLAIMS AND MAKES NO WARRANTY, EXPRESS, STATUTORY OR IMPLIED, INCLUDING THE IMPLIED WARRANTIES OF MERCHANTABILITY AND FITNESS FOR PARTICULAR PURPOSE, WITH REGARD TO ANY CIRRUS PRODUCT THAT IS USED IN SUCH A MANNER. IF THE CUSTOMER OR CUSTOMER'S CUSTOMER USES OR PERMITS THE USE OF CIRRUS PRODUCTS IN CRITICAL APPLICATIONS, CUSTOMER AGREES, BY SUCH USE, TO FULLY INDEMNIFY CIRRUS, ITS OFFICERS, DIRECTORS, EMPLOYEES, DISTRIBUTORS AND OTHER AGENTS FROM ANY AND ALL LIABILITY, INCLUDING ATTORNEYS' FEES AND COSTS, THAT MAY RESULT FROM OR ARISE IN CONNECTION WITH THESE USES.

Cirrus Logic, Cirrus, and the Cirrus Logic logo designs are trademarks of Cirrus Logic, Inc. All other brand and product names in this document may be trademarks or service marks of their respective owners.

1. CHARACTERISTICS AND SPECIFICATIONS

- Min/Max characteristics and specifications are guaranteed over the Specified Operating Conditions.
- Typical performance characteristics and specifications are derived from measurements taken at nominal supply voltages and $T_A = 25^\circ\text{C}$.
- GND = 0 V, all voltages with respect to 0 V.
- Device connected as shown in [Figure 5](#) on page 12 unless otherwise noted.

SPECIFIED OPERATING CONDITIONS

Parameter	Symbol	Min	Nom	Max	Unit
Bipolar Power Supplies					
Positive Analog $\pm 2\%$	VA+	2.45	2.50	2.55	V
Negative Analog (Note 1) $\pm 2\%$	VA-	-2.55	-2.50	-2.45	V
Positive Digital (Note 2) $\pm 3\%$	VD	3.20	3.30	3.40	V
Thermal					
Ambient Operating Temperature Industrial (-IS, -ISZ)	T_A	-40	25	85	$^\circ\text{C}$

- Notes:
1. VA- must be the most negative voltage to avoid potential SCR latch-up conditions.
 2. VD must conform to Digital Supply Differential under Absolute Maximum Ratings.

ABSOLUTE MAXIMUM RATINGS

Parameter	Symbol	CS3302A		Unit	
		Min	Max		
DC Power Supplies	Positive Analog	VA+	-0.3	6.8	V
	Negative Analog	VA-	-6.8	0.3	V
	Digital	VD	-0.3	6.8	V
Analog Supply Differential [(VA+) - (VA-)]	V_{A_DIFF}	-	6.8	V	
Digital Supply Differential [(VD) - (VA-)]	V_{D_DIFF}	-	6.8	V	
Input Current, Any Pin Except Supplies (Note 3)	I_{IN}	-	± 10	mA	
Input Current, Power Supplies (Note 3)	I_{PWR}	-	± 50	mA	
Output Current (Note 3)	I_{OUT}	-	± 25	mA	
Power Dissipation	PD	-	500	mW	
Analog Input Voltages	V_{INA}	(VA-)-0.5	(VA+)+0.5	V	
Digital Input Voltages	V_{IND}	-0.5	(VD)+0.5	V	
Storage Temperature Range	T_{STG}	-65	150	$^\circ\text{C}$	

WARNING: Operation at or beyond these limits may result in permanent damage to the device.
Normal operation is not guaranteed at these extremes.

- Notes:
3. Transient currents up to 100mA will not cause SCR latch-up.

THERMAL CHARACTERISTICS

Parameter	Symbol	CS3302A			Unit
		Min	Typ	Max	
Storage Temperature Range	T_{STR}	-65	-	150	°C
Allowable Junction Temperature		-	-	125	°C
Junction to Ambient Thermal Impedance	Θ_{JA}	-	65	-	°C / W
Ambient Operating Temperature	T_A	-40	-	+85	°C

ANALOG CHARACTERISTICS

Parameter	Symbol	CS3302A			Unit	
		Min	Typ	Max		
Noise Performance						
Input Voltage Noise	$f_0 = 0.1 \text{ Hz to } 10 \text{ Hz}$	V_{NPP}	-	1	3	μV_{pp}
Input Voltage Noise Density	$f_0 = 200 \text{ Hz to } 2 \text{ kHz}$	V_{ND}	-	8.5	12	nV/\sqrt{Hz}
Input Current Noise Density	(Note 4)	I_{ND}	-	20	-	fA/\sqrt{Hz}
Distortion Performance						
Total Harmonic Distortion (Note 5)	x1	THD	-	-118	-112	dB
	x2		-	-119	-	
	x4		-	-119	-	
	x8		-	-119	-	
	x16		-	-118	-	
	x32		-	-115	-	
	x64		-	-112	-	
Linearity (Note 5)	x1	LIN	-	0.0001259	0.0002512	%
	x2		-	0.0001122	-	
	x4		-	0.0001122	-	
	x8		-	0.0001122	-	
	x16		-	0.0001259	-	
	x32		-	0.0001778	-	
	x64		-	0.0002512	-	

Notes: 4. Guaranteed by design and/or characterization.

5. Tested with a 31.25 Hz sine wave at -1 dB amplitude.

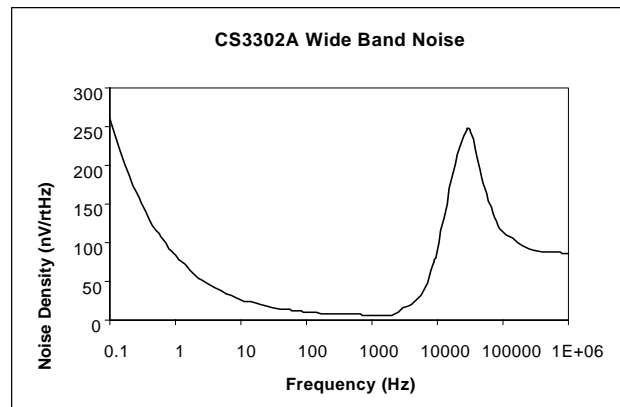
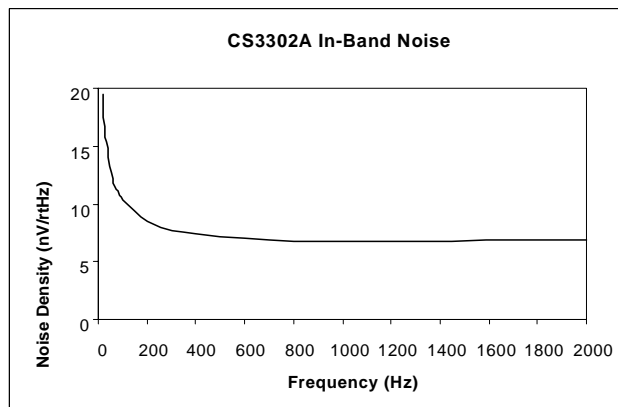

Figure 1. CS3302A Noise Performance

ANALOG CHARACTERISTICS (CONT.)

Parameter	Symbol	CS3302A			Unit	
		Min	Typ	Max		
Gain						
Gain, Differential	GAIN	x1	-	x64		
Gain, Common Mode (Note 6)	GAIN _{CM}	-	x1	-		
Gain Accuracy, Absolute (Note 7)	GAIN _{ABS}	-	±1	±2	%	
Gain Accuracy, Relative (Note 8)	LIN	x2	-0.4	-0.2	0	%
		x4	-	-0.2	-	
		x8	-	-0.2	-	
		x16	-	-0.2	-	
		x32	-	-0.2	-	
		x64	-	-0.2	-	
Gain Drift (Note 4, 9)	GAIN _{TC}	-	5	-	ppm / °C	
Offset						
Offset Voltage, Input Referred (Note 10)	OFST	-	±250	±750	µV	
Offset After Calibration, Absolute (Note 11)	OFST _{CAL}	-	±1	-	µV	
Offset Calibration Range (Note 12)	OFST _{RNG}	-	100	-	% F.S.	
Offset Voltage Drift (Note 4, 9)	OFST _{TC}	-	1	-	µV / °C	

- Notes:
6. Common mode signals pass unchanged through the differential amplifier architecture and are rejected by the CS5371A / 72A / 73A modulator CMRR.
 7. Absolute gain accuracy tests the matching of x1 gain across multiple CS3302A devices.
 8. Relative gain accuracy tests the tracking of x1,x2, x4,x16,x32,x64 gain relative to x1 gain on a single CS3302A device.
 9. Specification is for the parameter over the specified temperature range and is for the CS3302A device only. It does not include the effects of external components.
 10. Offset voltage is tested with the amplifier inputs connected to the internal 800Ω termination.
 11. The absolute offset after calibration specification applies to the effective offset voltage of the CS3302A output when used with the CS5371A / 72A / 73A modulator and the CS5376A / 78 digital filter, and is measured from the digitally calibrated output codes of the CS5376A / 78.
 12. The CS3302A offset calibration is performed digitally with the CS5371A / 72A / 73A modulator and CS5376A / 78 digital filter and includes the full scale signal range. Calibration offsets of greater than ± 5% of full scale will begin to subtract from system dynamic range.

ANALOG CHARACTERISTIC (Cont.)

Parameter	Symbol	CS3302A			Unit	
		Min	Typ	Max		
Analog Input Characteristics						
Input Signal Frequencies	BW	DC	-	2000	Hz	
Input Voltage Range (Signal + Vcm)	x1 x2 - x64	V _{IN}	(VA-)+0.7 (VA-)+0.7	- -	(VA+)-1.25 (VA+)-1.75	V
Full Scale Input, Differential	x1 x2 x4 x8 x16 x32 x64	V _{INFS}	- - - - - - -	- - - - - - -	5 2.5 1.25 625 312.5 156.25 78.125	V _{p-p} V _{p-p} V _{p-p} mV _{p-p} mV _{p-p} mV _{p-p} mV _{p-p}
Input Impedance, Differential		Z _{INDIFF}	-	1, 20	-	TΩ, pF
Input Impedance, Common Mode		Z _{INCM}	-	0.5, 40	-	TΩ, pF
Input Bias Current		I _{IN}	-	1	40	pA
Crosstalk, Multiplexed Inputs (Note 4)		XT	-	-130	-	dB
Common to Differential Mode Rejection (Note 4, 13)		CDMR	90	100	-	dB
Analog Output Characteristics						
Full Scale Output, Differential		V _{OUT}	-	-	5	V _{pp}
Output Voltage Range (Signal + Vcm)		V _{RNG}	(VA-)+0.5	-	(VA+)-0.5	V
Output Impedance (Note 14)		Z _{OUT}	-	40	-	Ω
Output Impedance Drift (Note 14)		Z _{TC}	-	0.38	-	Ω/°C
Output Current		I _{OUT}	-	-	±25	mA
Load Capacitance		C _L	-	-	100	nF
Guard Output Characteristics						
Guard Output Voltage		V _{GUARD}	-	V _{cm}	-	V
Guard Output Impedance		Z _{GOUT}	-	500	-	Ω
Guard Output Current		I _{GOUT}	-	40	-	μA
Guard Load Capacitance		C _{GL}	-	-	100	pF

Notes: 13. Ratio of common mode input amplitude vs. differential mode output amplitude for a perfectly matched common mode input signal. Characterized with a 50 Hz, 500 mV_{peak} common mode sine wave applied to the analog inputs.

14. Output impedance characteristics are approximate and can vary up to +/- 30% depending on process parameters.

DIGITAL CHARACTERISTICS

Parameter	Symbol	CS3302A			Unit
		Min	Typ	Max	
Digital Characteristics					
High-level Input Drive Voltage (Note 15)	V_{IH}	0.6*VD	-	VD	V
Low-level Input Drive Voltage (Note 15)	V_{IL}	0.0	-	0.8	V
Input Leakage Current	I_{IN}	-	±1	±10	µA
Digital Input Capacitance	C_{IN}	-	9	-	pF
Rise Times	t_{RISE}	-	-	100	ns
Fall Times	t_{FALL}	-	-	100	ns

Notes: 15. Device is intended to be driven with CMOS logic levels.

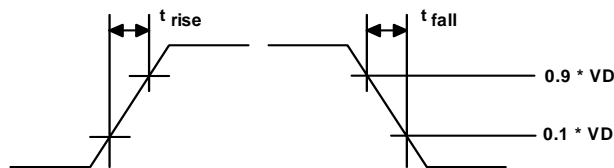

Figure 2. Digital Input Rise and Fall Times

Input Selection	MUX1	MUX0
800 Ω termination	0	0
INA only	1	0
INB only	0	1
INA + INB	1	1

Gain Selection	GAIN2	GAIN1	GAIN0
x1	0	0	0
x2	0	0	1
x4	0	1	0
x8	0	1	1
x16	1	0	0
x32	1	0	1
x64	1	1	0
Reserved	1	1	1

Table 1. Digital Selection for Gain and Input Mux Control

POWER SUPPLY CHARACTERISTICS

Parameter	Symbol	CS3302A			Unit
		Min	Typ	Max	
Power Supply Current, Normal Mode					
Analog Power Supply Current (Note 16)	I_A	-	5.0	5.75	mA
Digital Power Supply Current (Note 16)	I_D	-	0.1	0.2	mA
Power Supply Current, Power Down Mode					
Analog Power Supply Current, PWDN = 1 (Note 16)	I_A	-	9	11	μ A
Digital Power Supply Current, PWDN = 1 (Note 16)	I_D	-	2	8	μ A
Power Supply Rejection					
Power Supply Rejection Ratio (Note 4, 17)	PSRR	95	120	-	dB

Notes: 16. All outputs unloaded. Analog inputs connected to the internal 800 Ω termination. Digital inputs forced to VD or GND respectively.

17. Power supply rejection characterized with a 50 Hz, 400 mV_{pp} sine wave applied separately to each supply.

2. GENERAL DESCRIPTION

The CS3302A is a high-impedance, low-noise CMOS differential input, differential output amplifier for precision analog signals between DC and 2 kHz. It has multiplexed inputs, rough/fine charge outputs, and programmable gains of x1, x2, x4, x8, x16, x32, and x64.

The performance of this amplifier makes it ideal for low-frequency, high-dynamic-range applications requiring low distortion and minimal power consumption. It is optimized for use in acquisition systems designed around the CS5371A/72A single/dual $\Delta\Sigma$ modulators and the CS5376A quad digital filter or the CS5373A $\Delta\Sigma$ modulator and CS5378 digital filter. [Figure 3](#) shows the system-level architecture of a 4-channel acquisition system using four CS3302A, two CS5372A, one CS4373A, and one CS5376A. [Figure 4](#) shows the

system architecture of a single channel acquisition system using a CS3302A, CS5373A, and CS5378.

2.1 Analog Signals

2.1.1 Analog Inputs

The amplifier analog inputs are designed for high-impedance differential sensors. Input multiplexing simplifies system connections by providing separate inputs for a sensor and test DAC (INA, INB) as well as an internal termination for noise tests. The MUX0, MUX1 digital pins determine which multiplexed input is connected to the amplifier.

2.1.2 Analog Outputs

The amplifier analog outputs are separated into rough charge / fine charge signals to easily connect to the CS5371A/72A/73A inputs. Each differential output

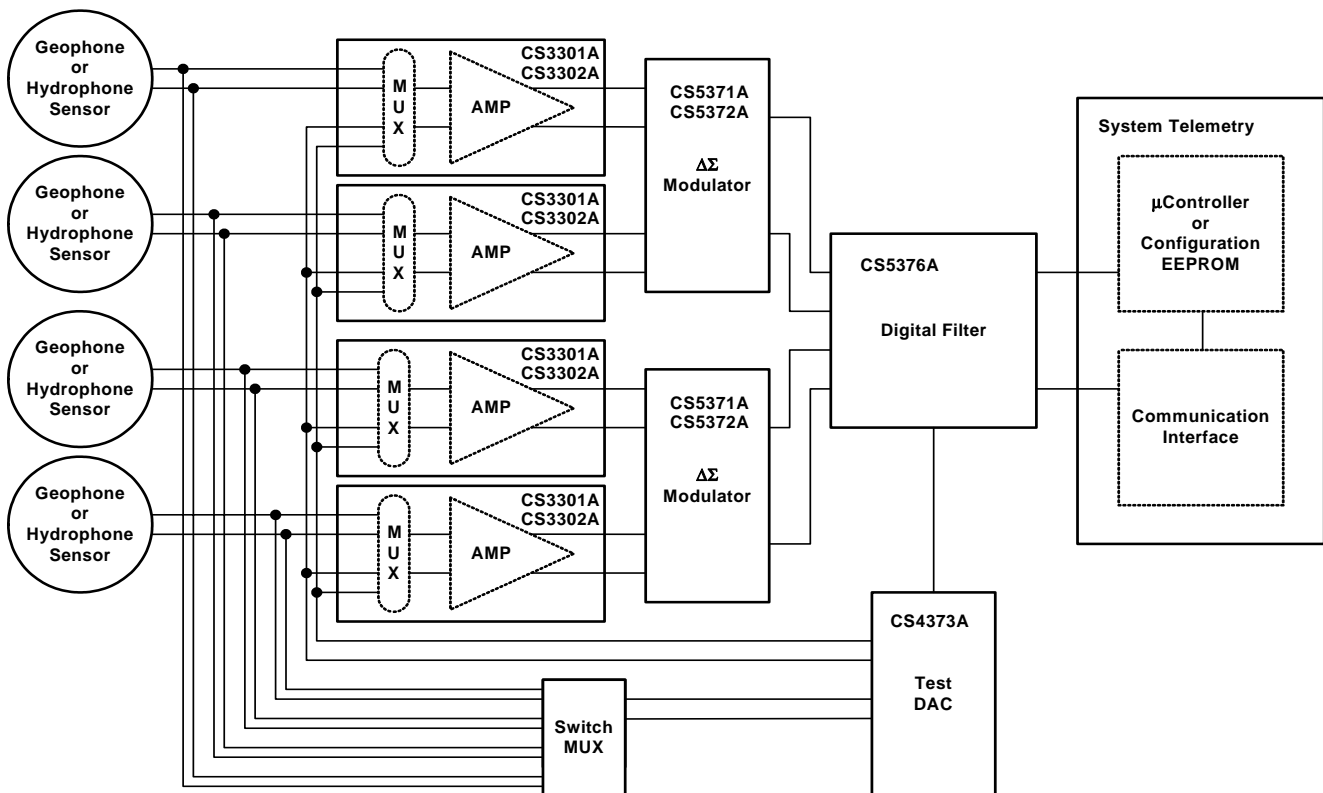

Figure 3. System Architecture

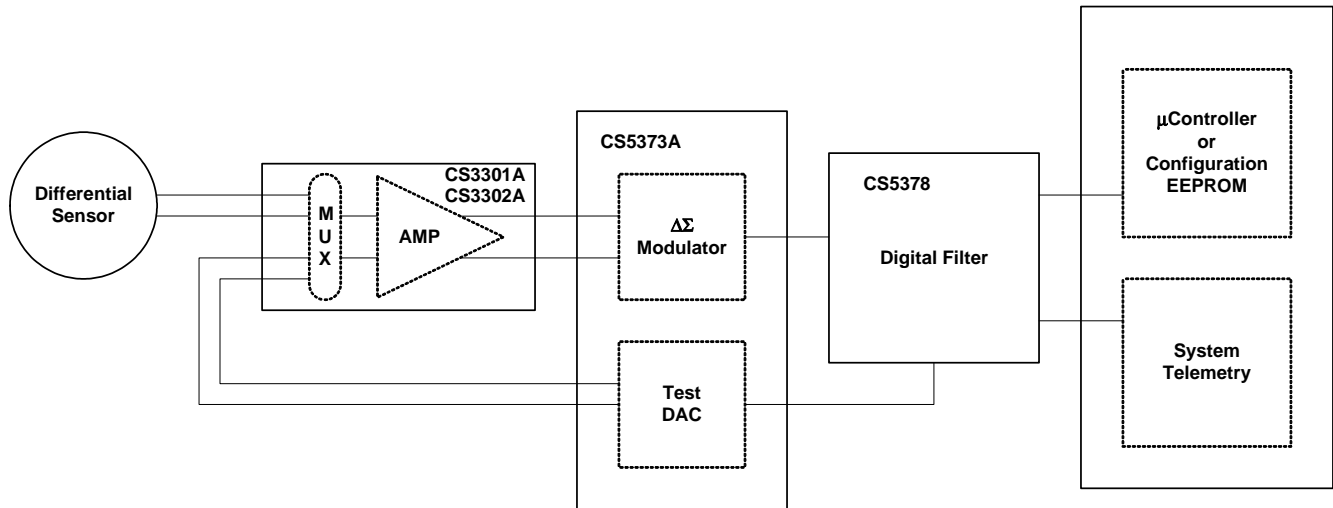

Figure 4. System Architecture

requires two series resistors and a differential capacitor to create the modulator anti-alias RC filter.

2.1.3 Differential Signals

Analog signals into and out of the CS3302A are differential, consisting of two halves with equal but opposite magnitude varying about a common mode voltage.

A full scale $5 V_{pp}$ differential signal centered on a $-0.15 V$ common mode can have:

$$SIG+ = -0.15 V + 1.25 V = 1.1 V$$

$$SIG- = -0.15 V - 1.25 V = -1.4 V$$

SIG+ is $+2.5 V$ relative to SIG-

For the reverse case:

$$SIG+ = -0.15 V - 1.25 V = -1.4 V$$

$$SIG- = -0.15 V + 1.25 V = 1.1 V$$

SIG+ is $-2.5 V$ relative to SIG-

The total swing for SIG+ relative to SIG- is $(+2.5 V) - (-2.5 V) = 5 V_{pp}$. A similar calculation can be done for SIG- relative to SIG+. Note that a $5 V_{pp}$ differential signal centered on a $-0.15 V$ common mode voltage never exceeds $1.1 V$ and never drops below $-1.4 V$ on either half of the signal.

By definition, differential voltages are to be measured with respect to the opposite half, not relative to ground. A multimeter differentially measuring between SIG+ and SIG- in the above example would properly read $1.767 V_{rms}$, or $5 V_{pp}$.

2.1.4 Guard Output

The GUARD pin outputs the common mode voltage of the currently selected analog signal input. It can be used to drive the cable shield between a high-impedance sensor and the amplifier inputs. Driving the cable shield with the analog signal common mode voltage minimizes leakage and improves signal integrity from high-impedance sensors.

The GUARD output is defined as the midpoint voltage between the + and - halves of the currently selected differential input signal, and will vary as the signal common mode varies. The GUARD output will not drive a significant load, it only provides a shielding voltage.

2.2 Digital Signals

2.2.1 Gain Selection

The CS3302A supports gain ranges of x1, x2, x4, x8, x16, x32, and x64. They are selected using the GAIN0, GAIN1, and GAIN2 pins as shown in [Table 1 on page 8](#).

2.2.2 Mux Selection

The analog inputs to the amplifier are multiplexed, with external signals applied to the INA+, INA- or INB+, INB- pins. An internal termination is also available for noise tests. Input mux selection is made using the MUX0 and MUX1 pins as shown in [Table 1 on page 8](#).

Although a mux selection is provided to enable the INA and INB switches simultaneously, significant current should not be driven through them in this mode. The CS3302A mux switches will maintain good linearity only with minimal signal current.

2.2.3 Power Down Selection

A power-down mode is available to shut down the amplifier when not in use. When enabled, all internal circuitry is disabled, the analog inputs and outputs go high-impedance, and the device enters a micro-power state. Power down mode is selected using the PWDN pin, which is active high.

2.3 Power Supplies

2.3.1 Analog Power Supplies

The analog power pins of the CS3302A are to be supplied with a total of 5 V between VA+ and VA-. This voltage is typically from a bipolar ± 2.5 V supply. When using bipolar supplies the analog signal common mode voltage should be biased to 0 V. The analog power supplies are recommended to be bypassed to system ground using 0.1 μ F X7R type capacitors.

The VA- supply is connected to the CMOS substrate and as such must remain the most negative applied voltage to prevent potential latch-up conditions. It is recommended to clamp the VA- supply to system ground using a reverse biased Schottky diode to prevent possible latch-up conditions related to mismatched supply rail initialization.

2.3.2 Digital Power Supplies

The digital power supply across the VD and GND pins is specified for a +3.3 V power supply. The digital power supply should be bypassed to system ground using a 0.01 μ F X7R type capacitor.

2.4 Connection Diagram

Figure 5 shows a connection diagram for the CS3302A amplifier when used with the CS5372A dual $\Delta\Sigma$ modulator, the CS4373A test DAC and the CS5376A digital filter. The diagram shows differential sensors, a test DAC, and analog outputs with anti-alias capacitors; power supply connections including recommended bypassing; and digital control connections back to the CS5376A GPIO pins.

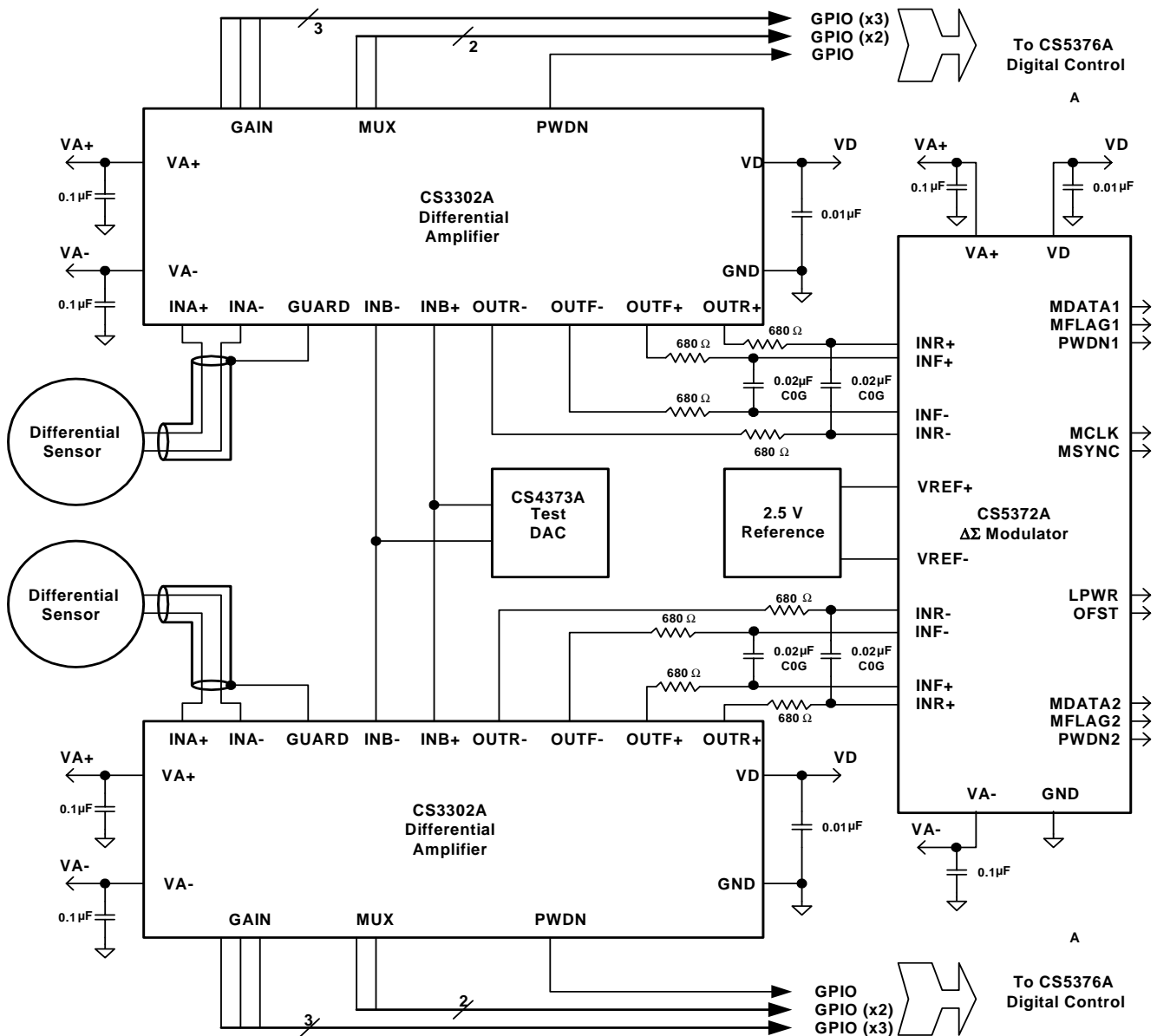

Figure 5. CS3302A Amplifier Connections

3. PIN DESCRIPTION

Pin Name	Pin #	I/O	Pin Description
VA+	1	I	Positive analog supply voltage.
VA-	4	I	Negative analog supply voltage.
VD	16	I	Positive digital supply voltage.
GND	15, 18	I	Ground.
INA+, INA-	5, 6	I	Channel A differential analog inputs. Selected via MUX pins.
INB+, INB-	8, 7	I	Channel B differential analog inputs. Selected via MUX pins.
GUARD	13	O	Guard voltage output.
OUTR+, OUTR-	11, 2	O	Rough charge differential analog outputs.
OUTF+, OUTF-	10, 3	O	Fine charge differential analog outputs.
GAIN0, GAIN1, GAIN2	22, 21, 20	I	Gain range select. See Gain Selection table in Digital Characteristics section.
PWDN	19	I	Power down mode enable. Active high.
MUX0, MUX1	24, 23	I	Analog input select. See Input Selection table in Digital Characteristics section.
TEST0	12	I	Test mode select, factory use only. Connect to VA- during normal operation.
TEST1, TEST2	17, 14	I	Test mode select, factory use only. Connect to GND during normal operation.
TESTOUT	9	O	Test mode output, factory use only. Do not connect during normal operation.

Table 2. Pin Descriptions

Positive Analog Power Supply	VA+	□ 1 •	24 □	MUX0	Input Mux Select
Negative Analog Rough Output	OUTR-	□ 2	23 □	MUX1	Input Mux Select
Negative Analog Fine Output	OUTF-	□ 3	22 □	GAIN0	Gain Range Select
Negative Analog Power Supply	VA-	□ 4	21 □	GAIN1	Gain Range Select
Non-Inverting Input A	INA+	□ 5	20 □	GAIN2	Gain Range Select
Inverting Input A	INA-	□ 6	19 □	PWDN	Power Down Mode Enable
Inverting Input B	INB-	□ 7	18 □	GND	Ground
Non-Inverting Input B	INB+	□ 8	17 □	TEST1	Test Mode Select
Test Mode Output	TESTOUT	□ 9	16 □	VD	Positive Digital Power Supply
Positive Analog Fine Output	OUTF+	□ 10	15 □	GND	Ground
Positive Analog Rough Output	OUTR+	□ 11	14 □	TEST2	Test Mode Select
Test Mode Select	TEST0	□ 12	13 □	GUARD	Guard Voltage Output

Figure 6. CS3302A Pin Assignments

4. ORDERING INFORMATION

Model	Temperature	Package
CS3302A-IS	-40 to +85 °C	24-pin SSOP
CS3302A-ISZ, lead (Pb) free		

5. ENVIRONMENTAL, MANUFACTURING, & HANDLING INFORMATION

Model Number	Peak Reflow Temp	MSL Rating*	Max Floor Life
CS3302A-IS	240 °C	2	365 Days
CS3302A-ISZ, lead (Pb) free	260 °C	3	7 Days

* MSL (Moisture Sensitivity Level) as specified by IPC/JEDEC J-STD-020.

6. PACKAGE DIMENSIONS

24 PIN SSOP PACKAGE DRAWING

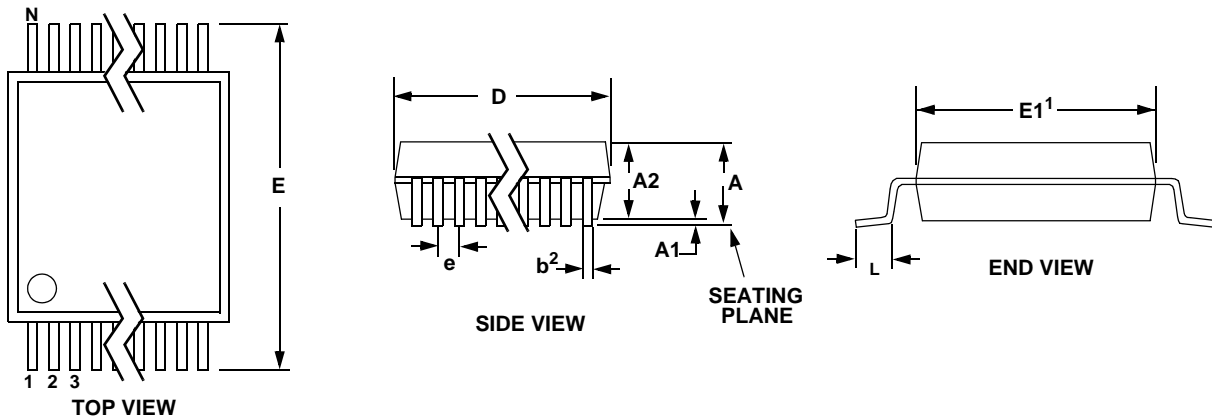

DIM	INCHES		MILLIMETERS		NOTE
	MIN	MAX	MIN	MAX	
A	--	0.084	--	2.13	
A1	0.002	0.010	0.05	0.25	
A2	0.064	0.074	1.62	1.88	
b	0.009	0.015	0.22	0.38	2,3
D	0.311	0.335	7.90	8.50	1
E	0.291	0.323	7.40	8.20	
E1	0.197	0.220	5.00	5.60	1
e	0.024	0.027	0.61	0.69	
L	0.025	0.040	0.63	1.03	
∞	0°	8°	0°	8°	

- Notes:
1. "D" and "E1" are reference datums and do not include mold flash or protrusions, but do include mold mismatch and are measured at the parting line, mold flash or protrusions shall not exceed 0.20 mm per side.
 2. Dimension "b" does not include dambar protrusion/intrusion. Allowable dambar protrusion shall be 0.13 mm total in excess of "b" dimension at maximum material condition. Dambar intrusion shall not reduce dimension "b" by more than 0.07 mm at least material condition.
 3. These dimensions apply to the flat section of the lead between 0.10 and 0.25 mm from lead tips.